



ENSEMBLE

HOSPITALITY DESIGN

SPRING 2018

MADISON MILLER



TABLE OF CONTENTS

EXISTING FLOOR PLANS.....	3
CONCEPT & GOALS.....	4
MOOD BOARD.....	5
IDEATION SKETCHES.....	6
IDEATION SKETCHES.....	7
BUBBLES, ADJACENCIES, ZONING.....	8
TABLE LAYOUTS.....	9
FIRST FLOOR PLAN.....	10
WAITING AREA.....	11
BAR RENDERINGS.....	12
BAR ANTHROPOMETRICS.....	13
RENDERINGS.....	14
RENDERINGS.....	15
BASEMENT FLOOR PLAN.....	16
REFLECTED CEILING PLANS.....	17
LIGHT MAPPING.....	18
LIGHT MAPPING.....	19
SWITCHING DIAGRAM.....	20
LUMINAIRE SCHEDULE & KEY.....	21

EXISTING FLOOR PLANS

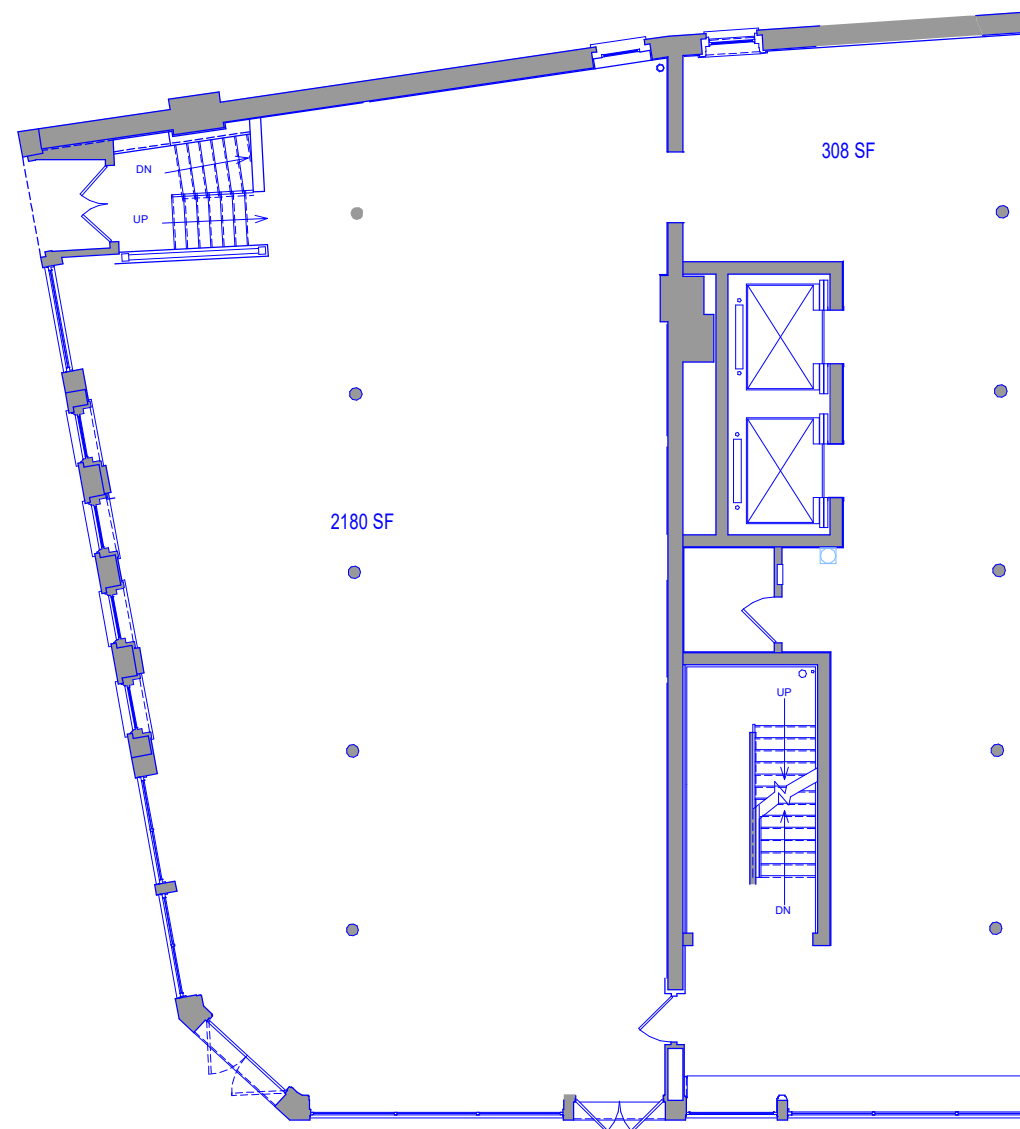

FIRST LEVEL

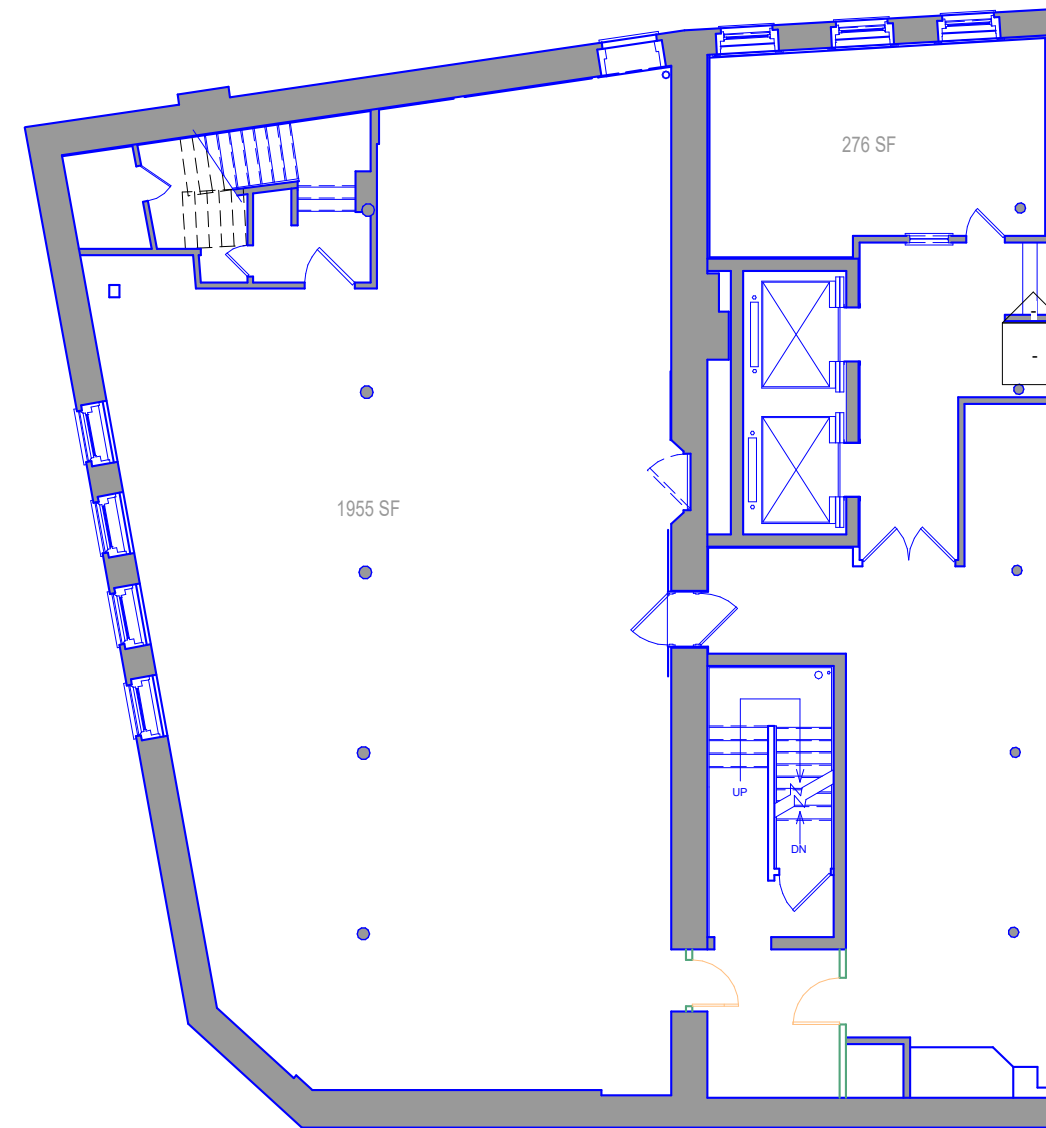

LOWER LEVEL

CONCEPT

A cabaret was once located in the basement of 151 St. Paul Street., which is exactly why this restaurant is all about a cabaret revival. Cabarets are known for their jazzy, classy, intimate, and social atmospheres, which will format the theme of a cabaret through the furniture, finishes, and lighting. From the menu to the atmosphere, guests will feel as if they are getting the experience of a real cabaret. The vintage feel of Ensemble brings back the past into the future.

GOALS AND LIMITATIONS

The client for this project is City Restaurant Group, who are looking to expand their brand with a new restaurant at 151 St. Paul Street in downtown Rochester, next to the Genesee River. The first floor and basement will be renovated to accommodate for this new restaurant. The concept for this restaurant comes from one of the previous uses of these floor, which will be the concept of a cabaret.

Goals

- Preserve the history of the building and site
- Maximize space on both floors
- Expand the City Restaurant Group brand

Objectives

- Careful use of lighting to replicate the atmosphere of a cabaret
- Use color and lighting to work together in order to support the cabaret concept

Limitations

- Connected to a hotel
- Circulation from first floor to basement
- Limitations of square footage of building

MOOD BOARD



IDEATION SKETCHES



back wall



corner

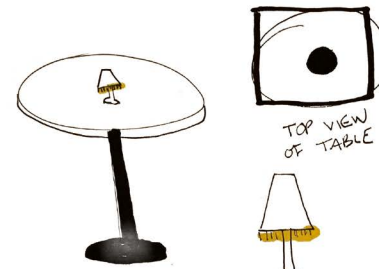
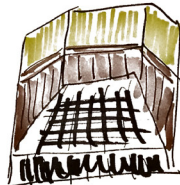
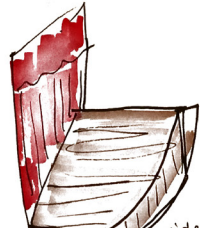

CABARET LAMPS



TOP VIEW OF TABLE



CHANDELIER IN WAITING AREA @ ENTRANCE

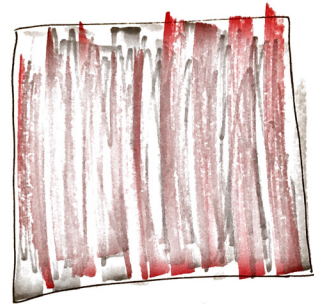

~ walls like Tony D's ~



curtains screw home

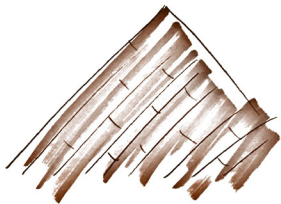

(ceiling) LED



MIRRORS or frames



BAR

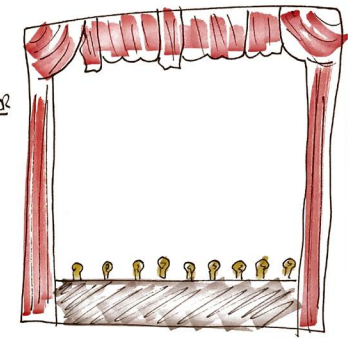

STAGE

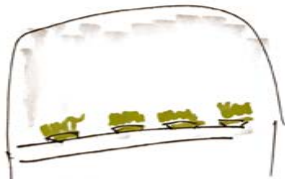
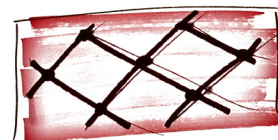
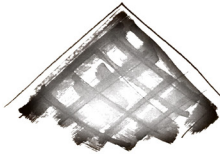

uplighting

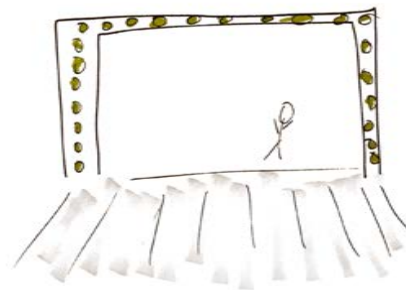

WAITING ROOM WALL - BRICK - ACCENT THE ARCHITECTURE

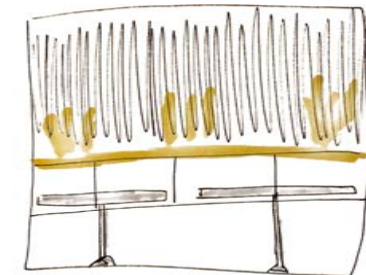

BANQUETTES ACCENT ARCHITECTURE

IDEATION SKETCHES

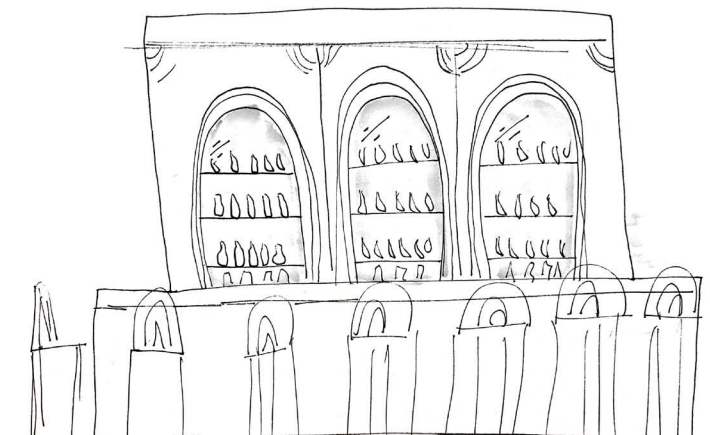
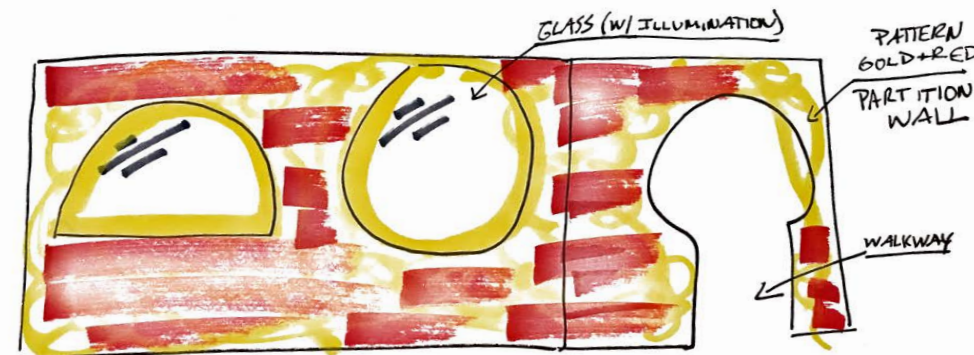
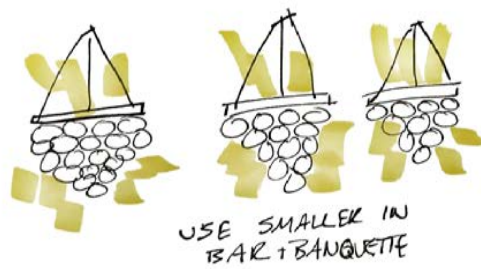
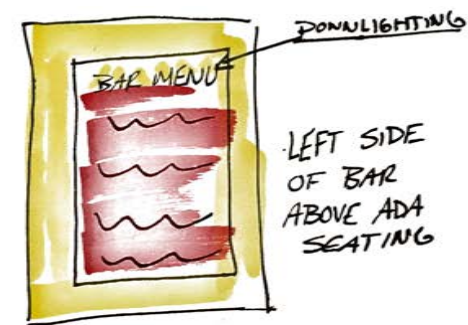
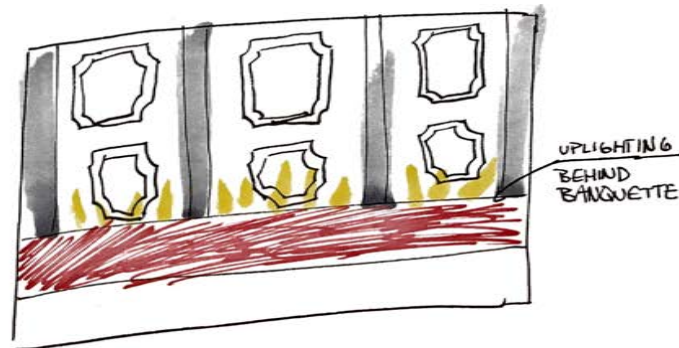
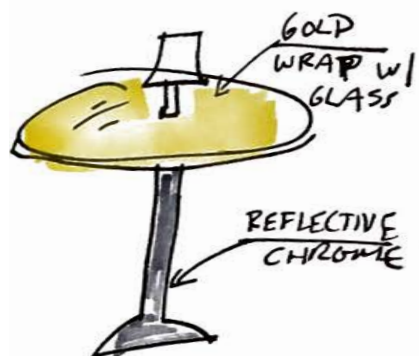
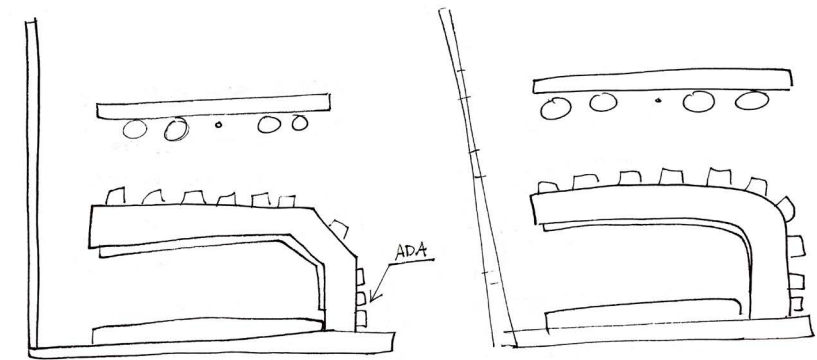
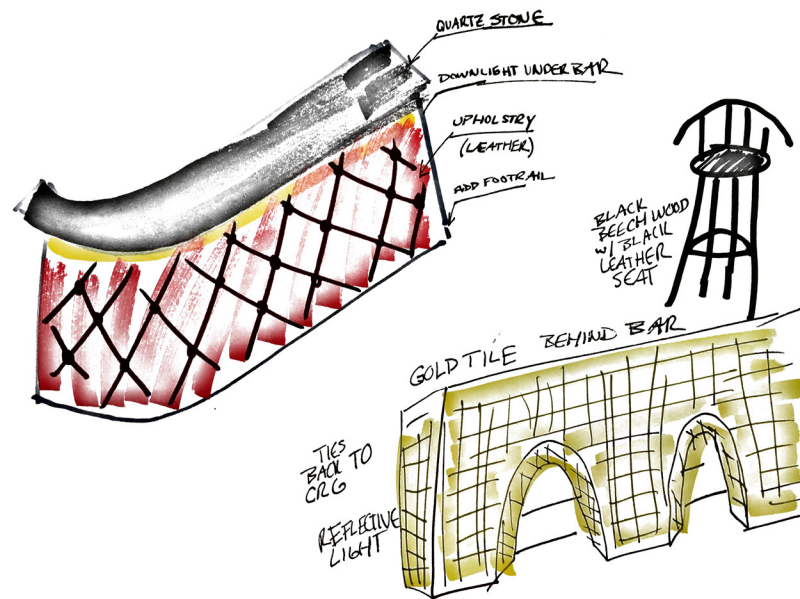
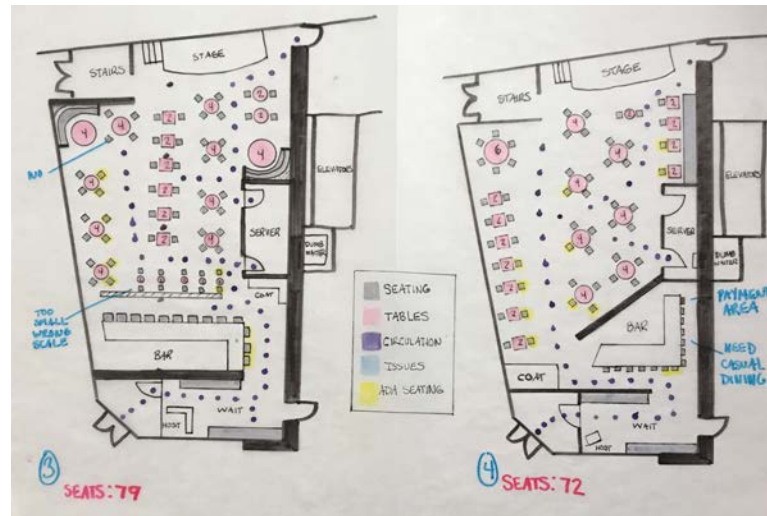

TABLE LAYOUTS



1

2



3

4



5

6

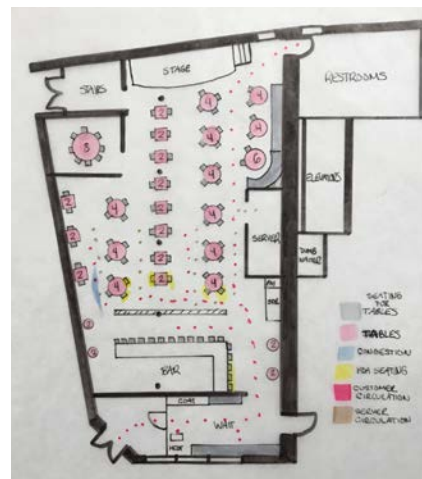

7



8

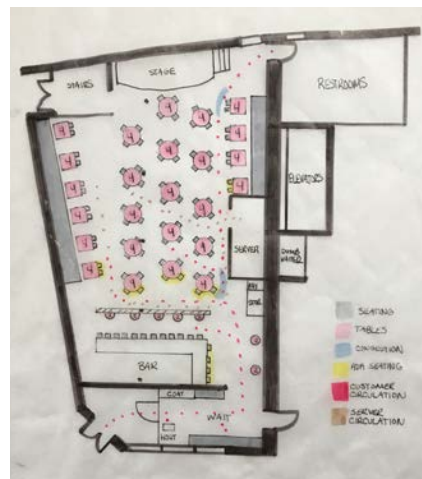

9

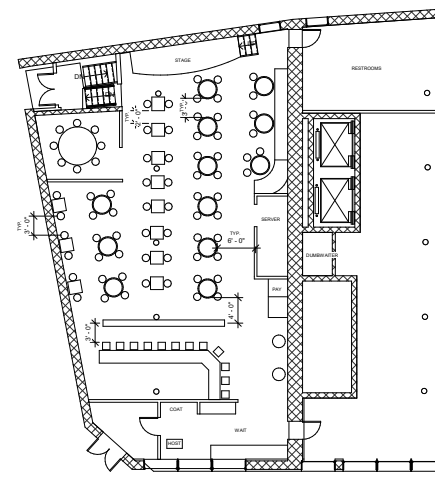

10

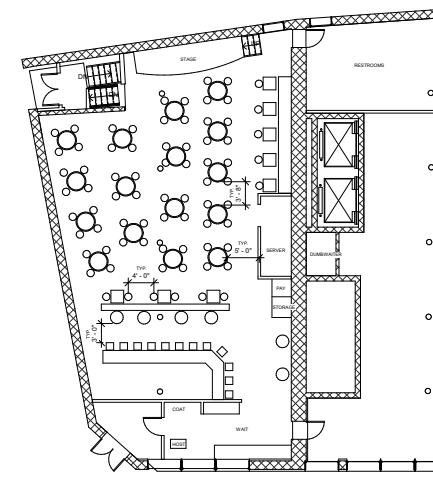

11

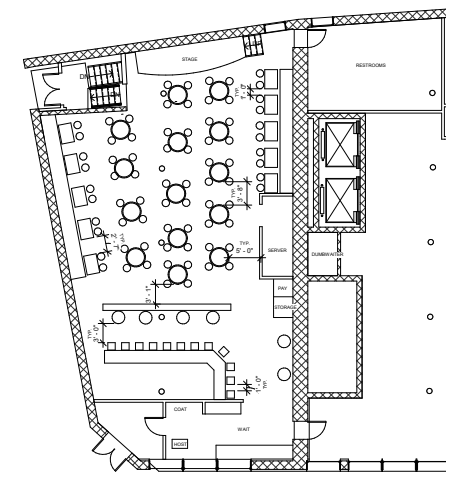

FINAL

FIRST LEVEL - FLOOR PLAN

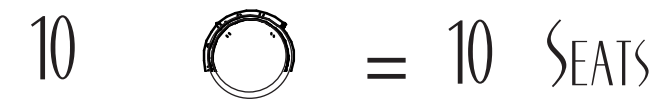
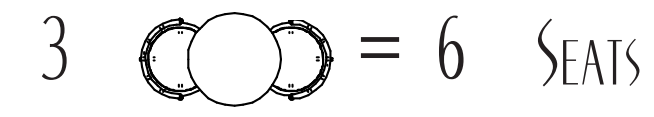
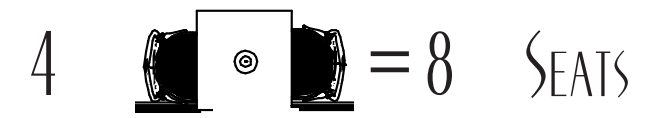
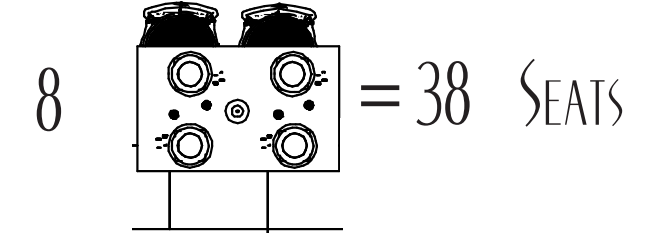
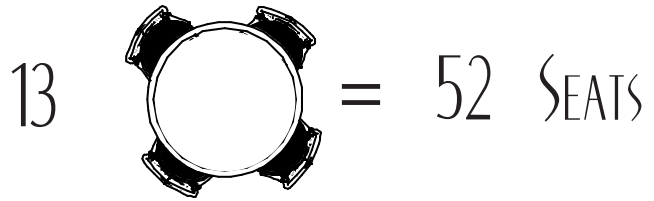

TOTAL SEATING: 114

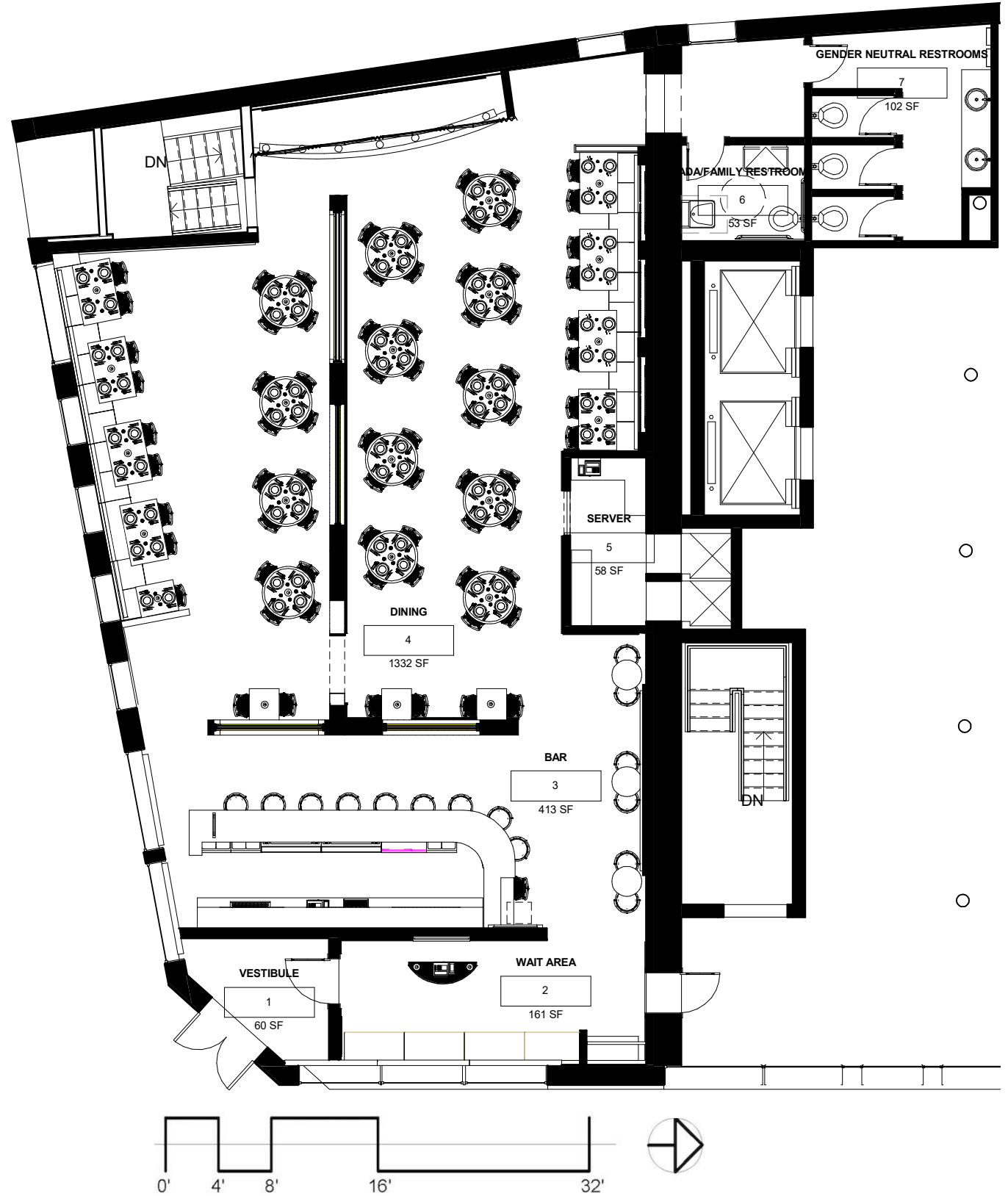

WAITING AREA

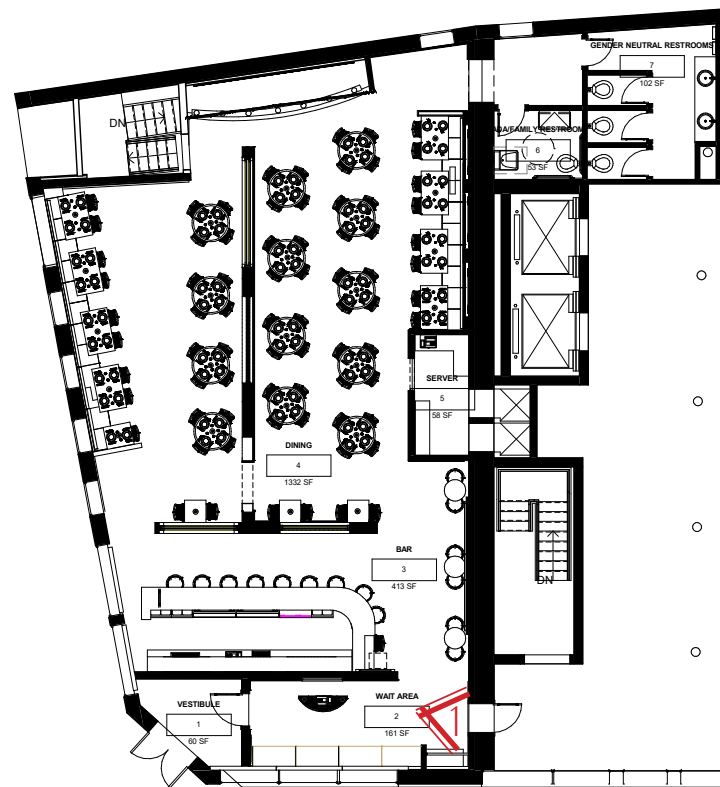
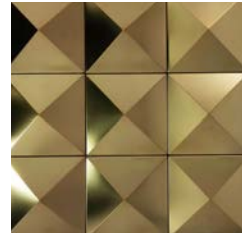
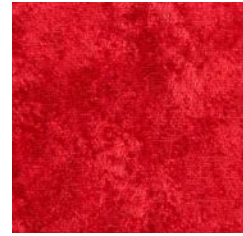

WAITING AREA

BAR RENDERINGS

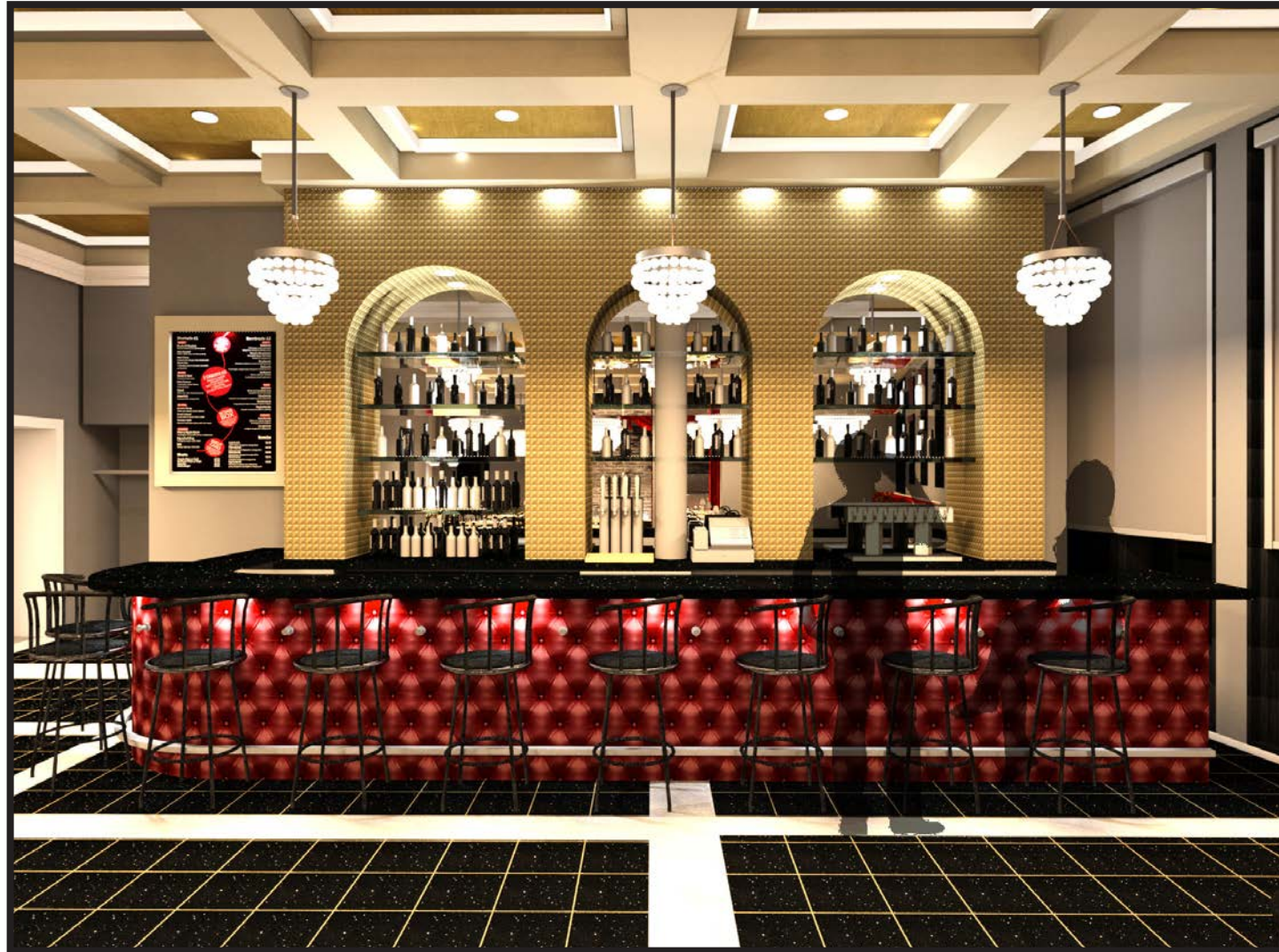

FRONT OF BAR

2

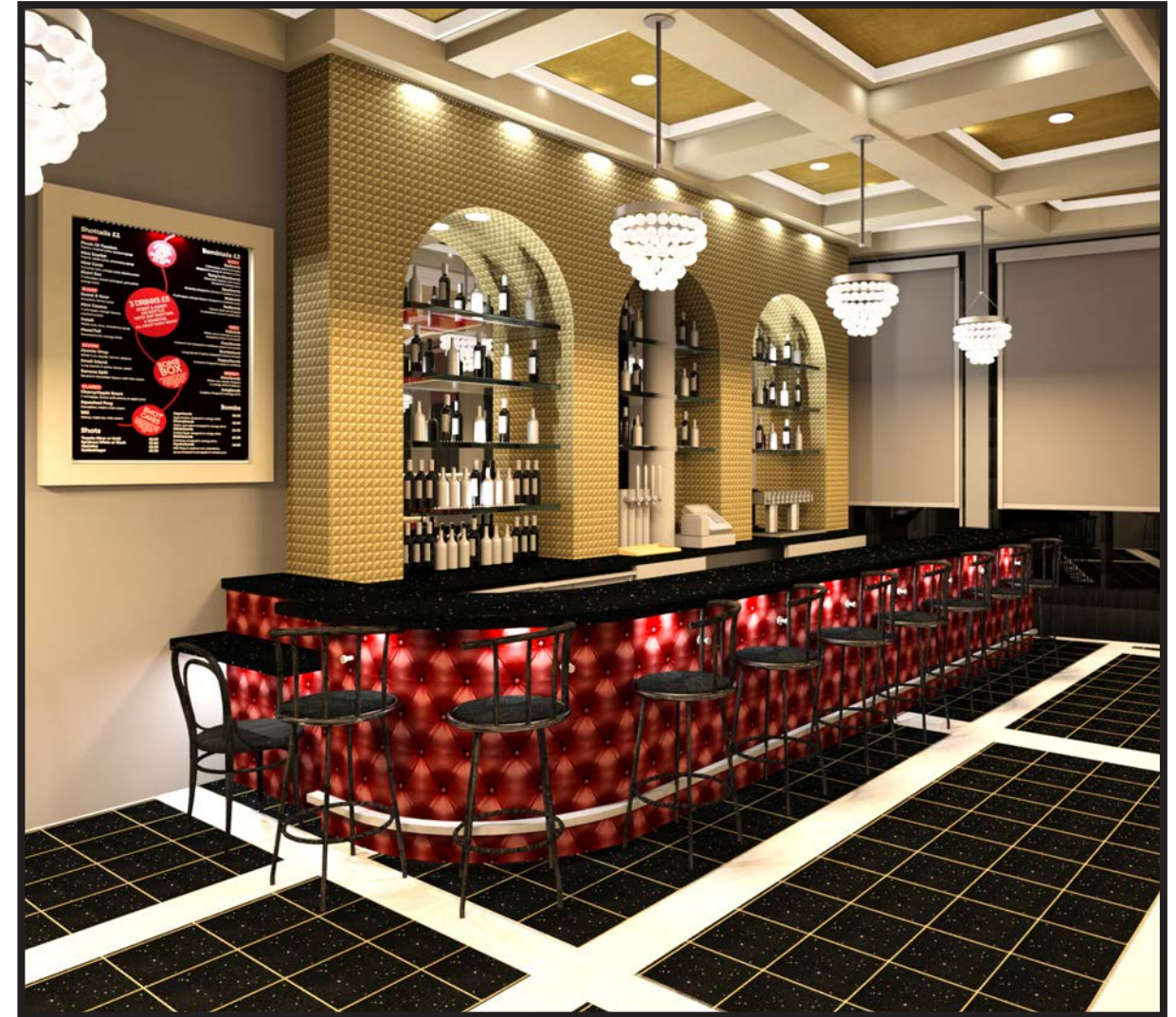

SIDE OF BAR

3

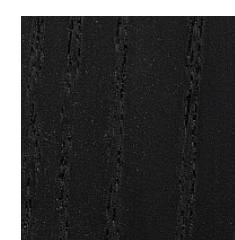
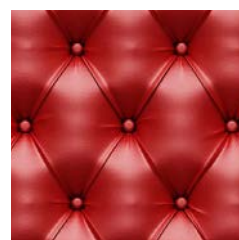

BAR ANTHROPOMETRICS

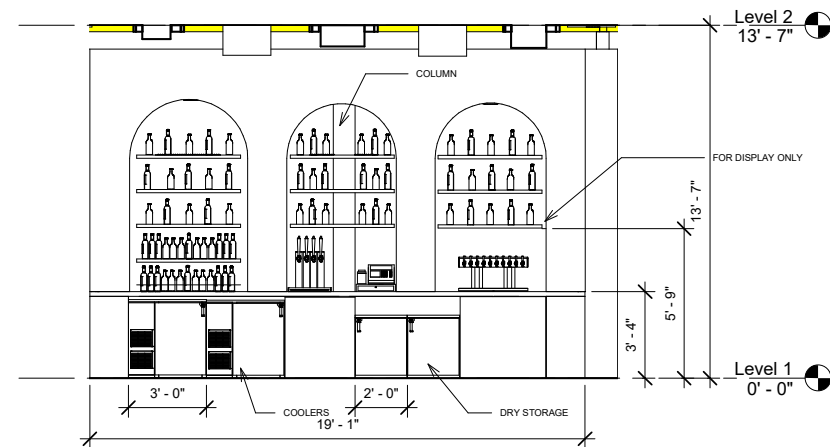
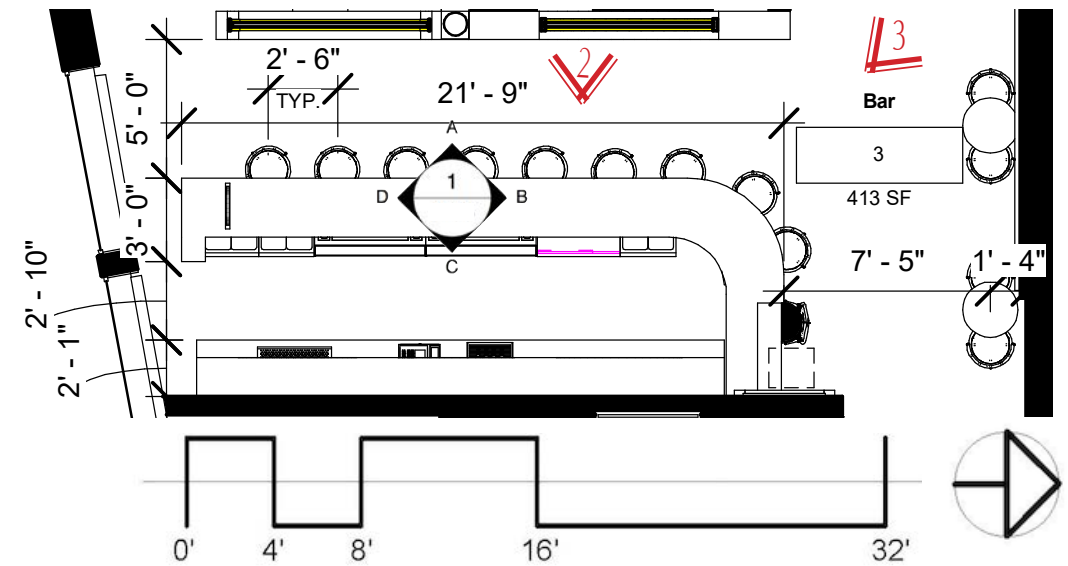

SECTION THROUGH BAR

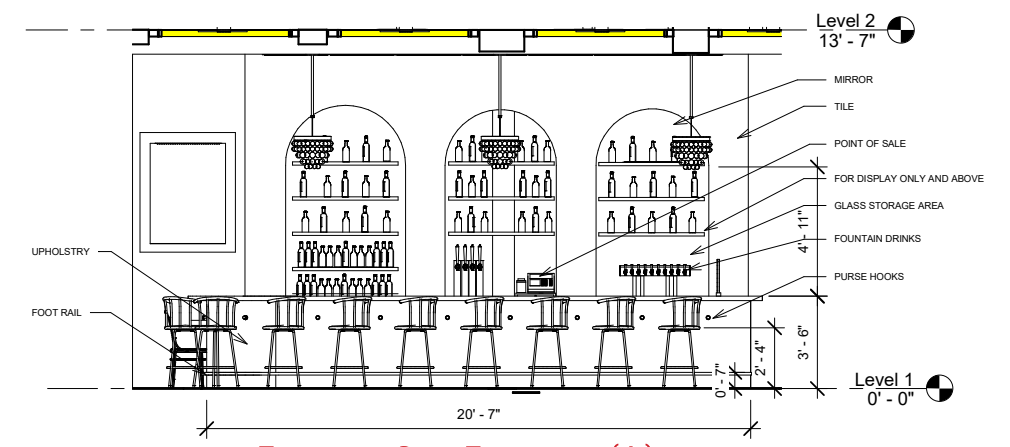

FRONT OF BAR ELEVATION (A)

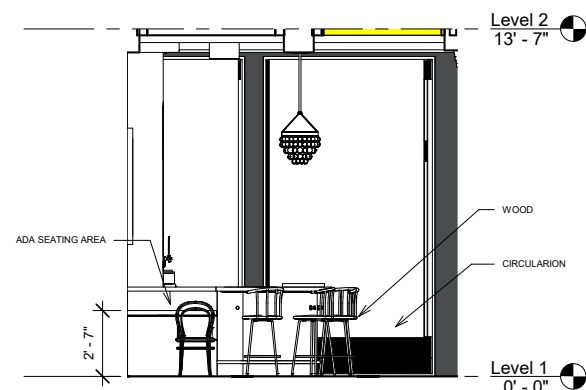

LEFT ELEVATION (B)

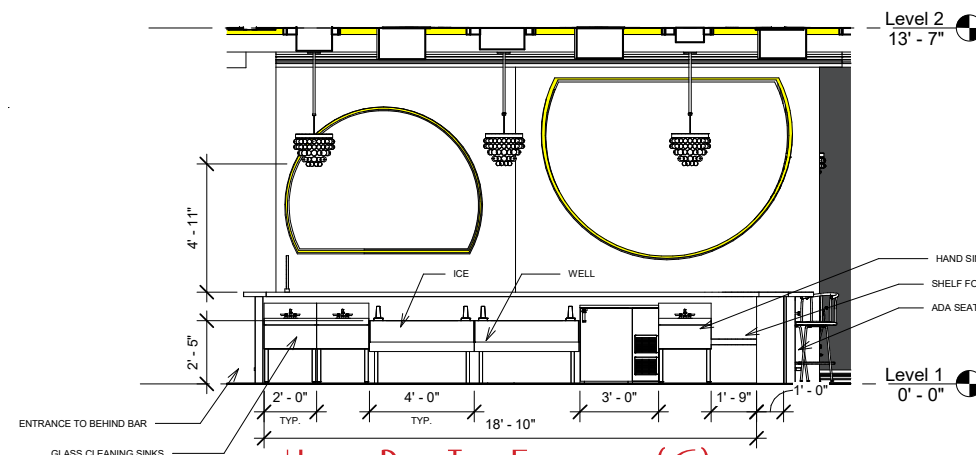

UNDER BAR TOP ELEVATION (C)

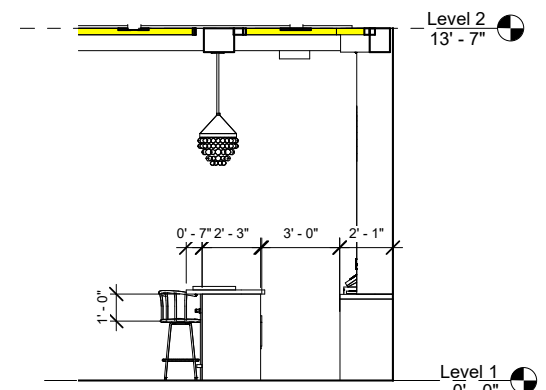

RIGHT ELEVATION (D)

RENDERINGS



STAGE DINING

4

RIGHT BANQUETTE

5

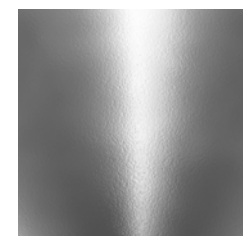
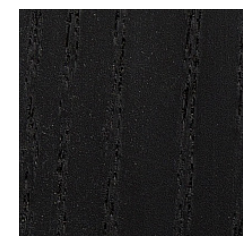
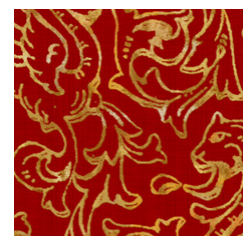

RENDERINGS

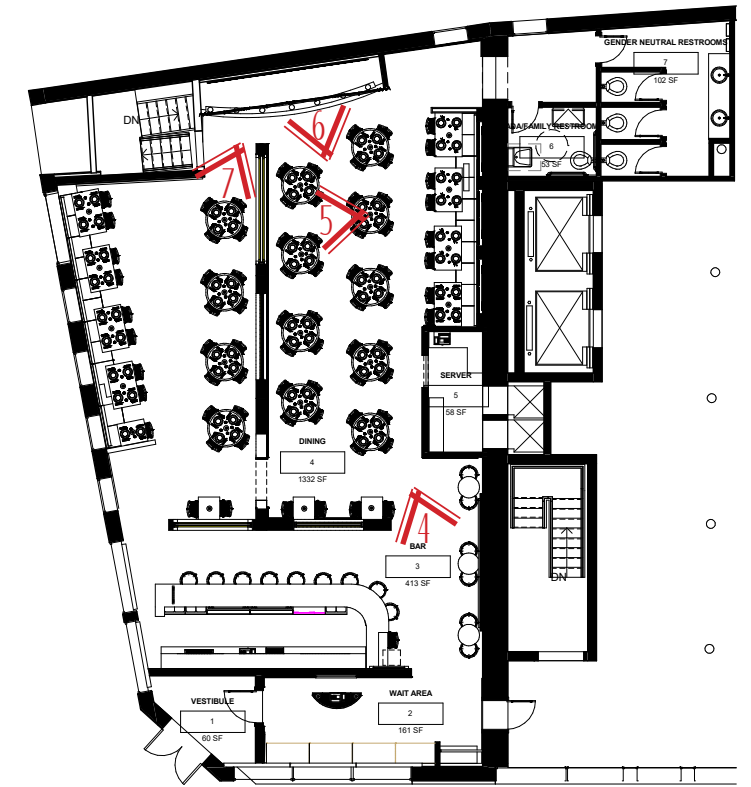

MAIN DINING

6

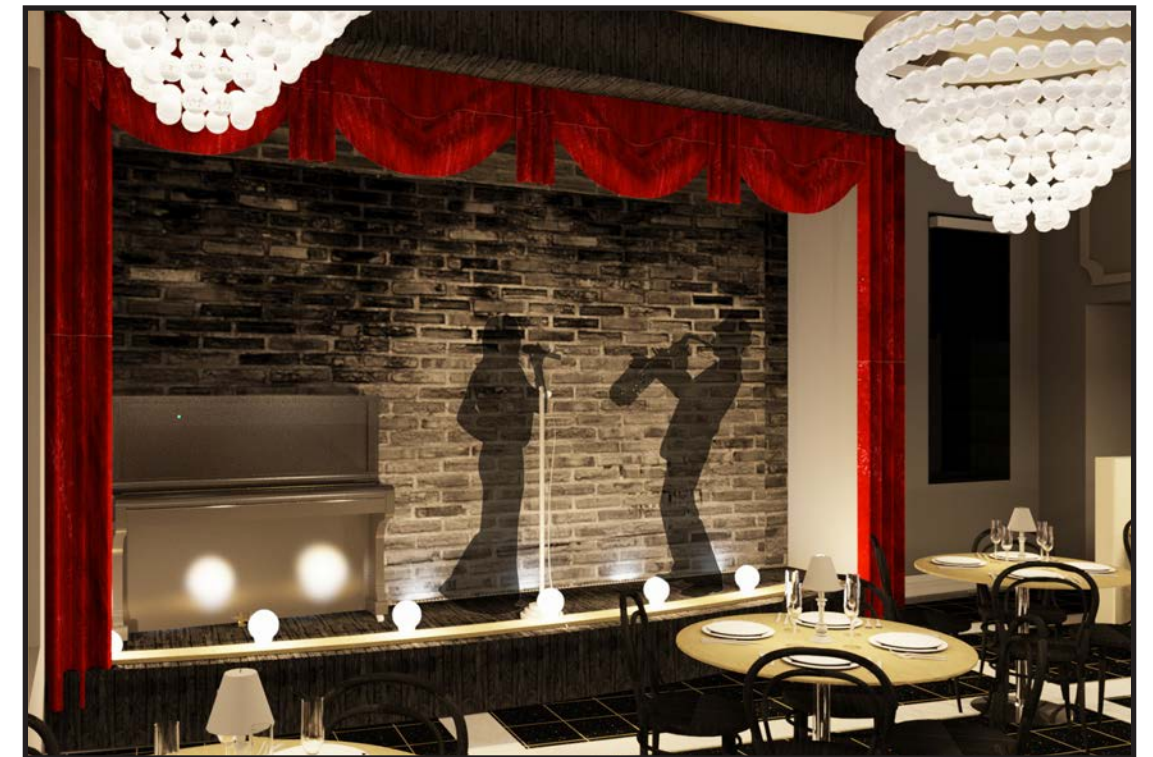

STAGE

7

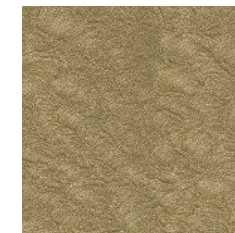
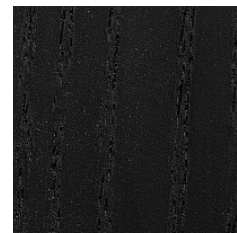
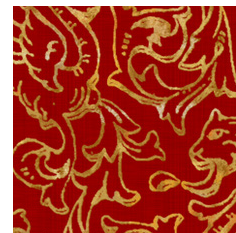

LOWER LEVEL FLOOR PLAN

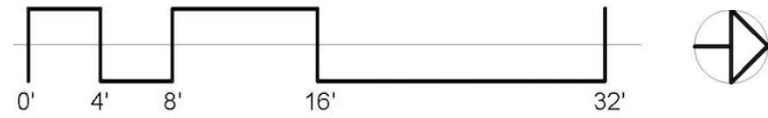
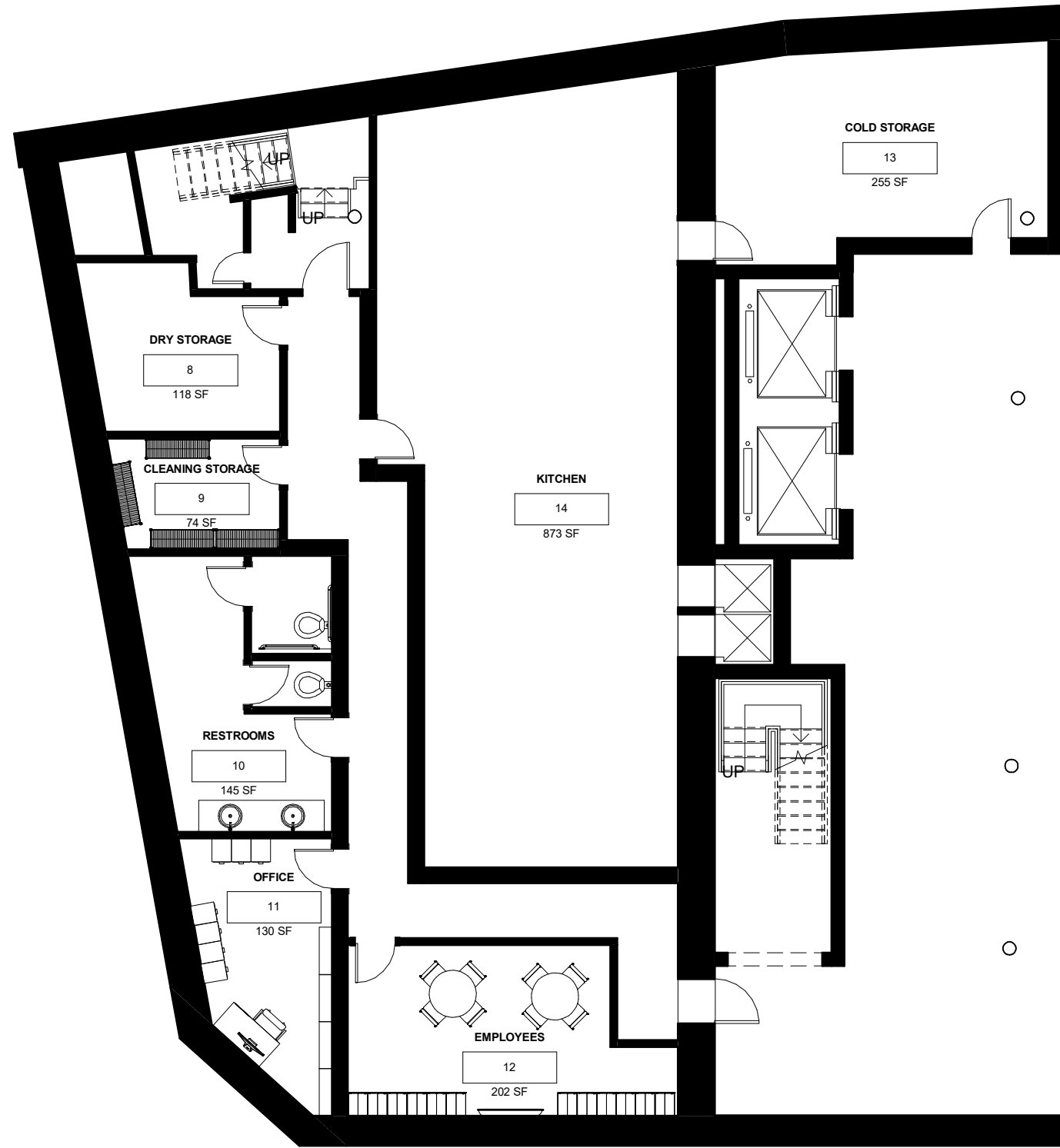

REFLECTED CEILING PLANS

FIRST FLOOR - RCP



LOWER LEVEL - RCP

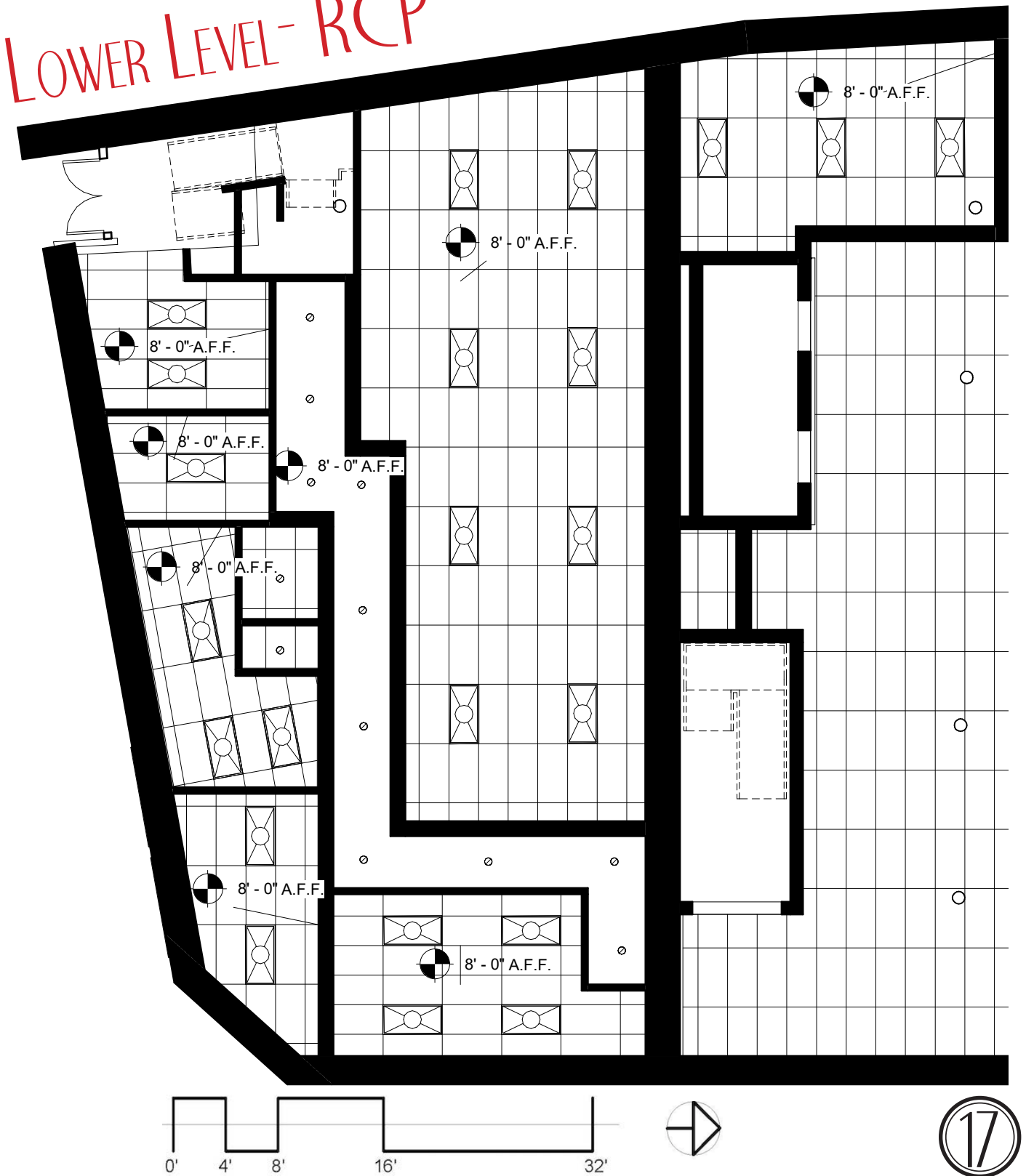

LIGHT MAPPING

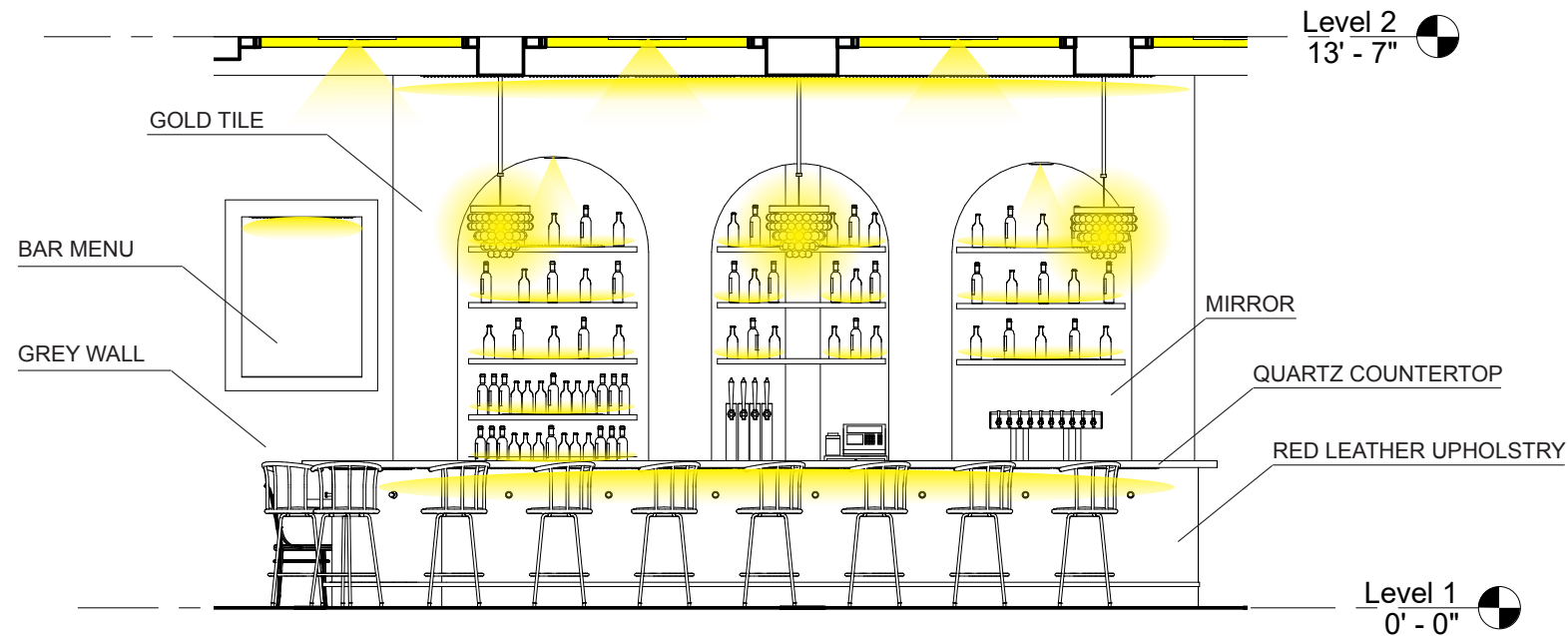

FRONT OF BAR

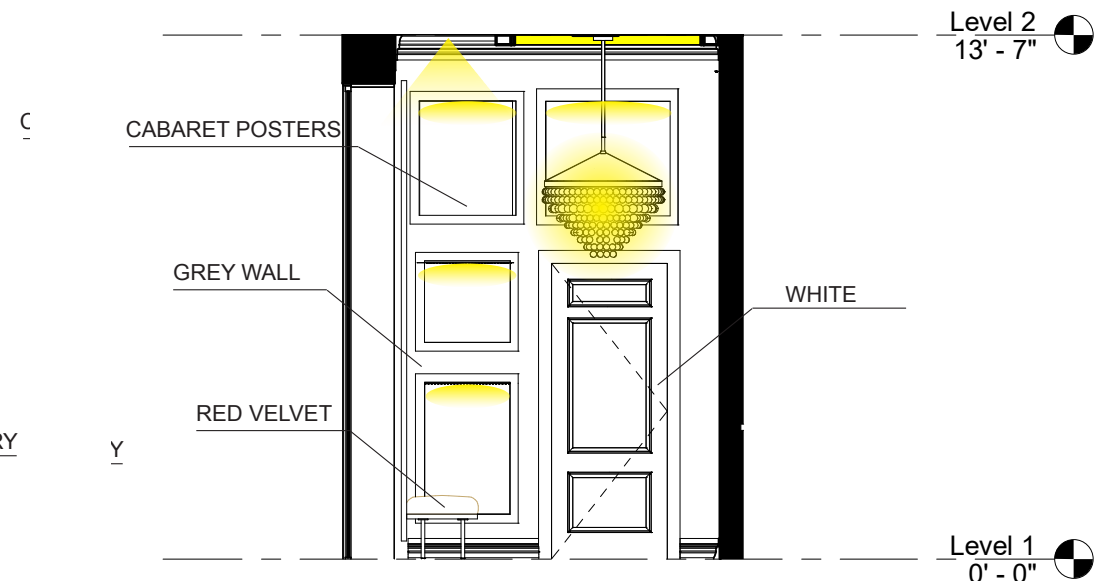

WAITING AREA

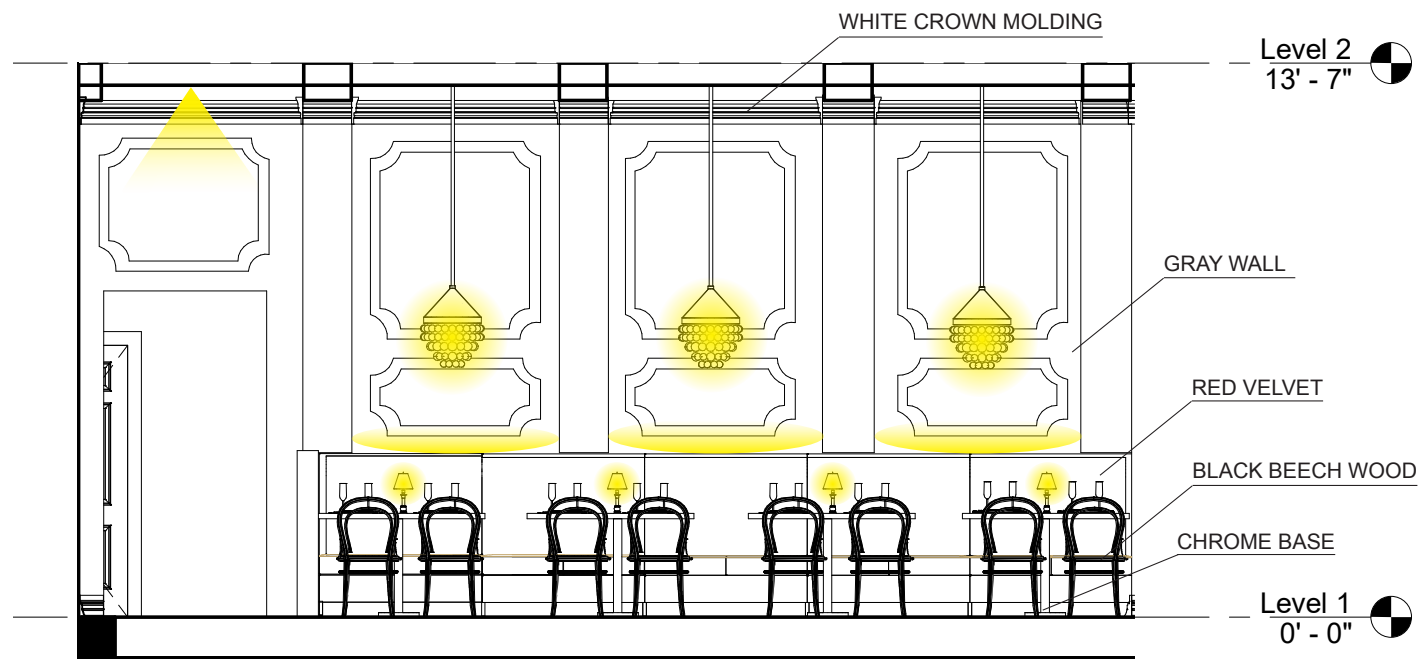

RIGHT BANQUETTE

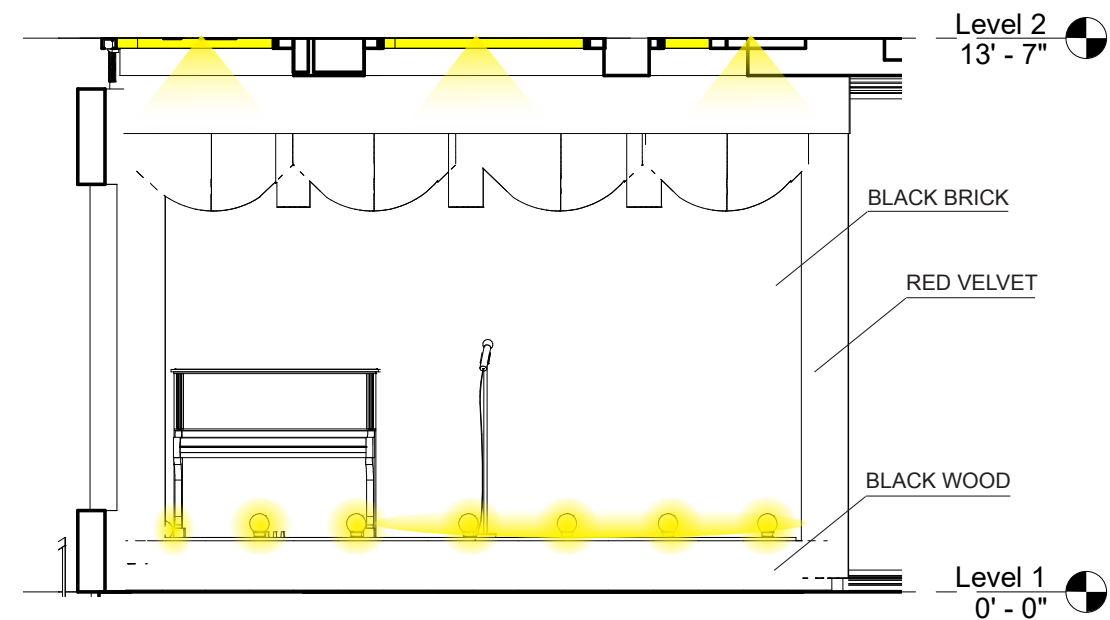



STAGE

KEY



LIGHT MAPPING

KEY

-  LIGHT ONTO HORIZONTAL SURFACE
-  LIGHT ONTO VERTICAL SURFACE
-  TASK LIGHTING



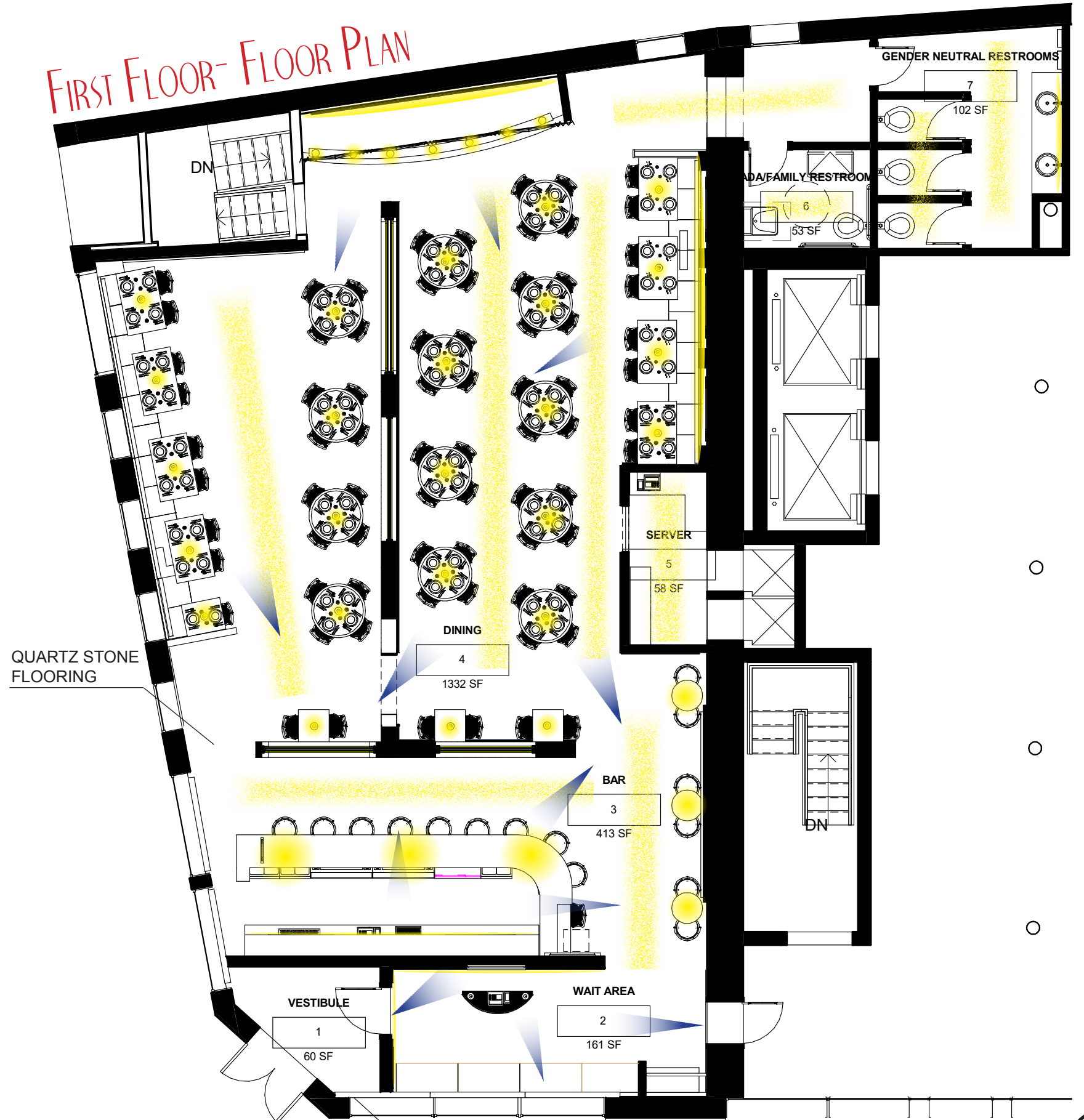

FIRST FLOOR- FLOOR PLAN

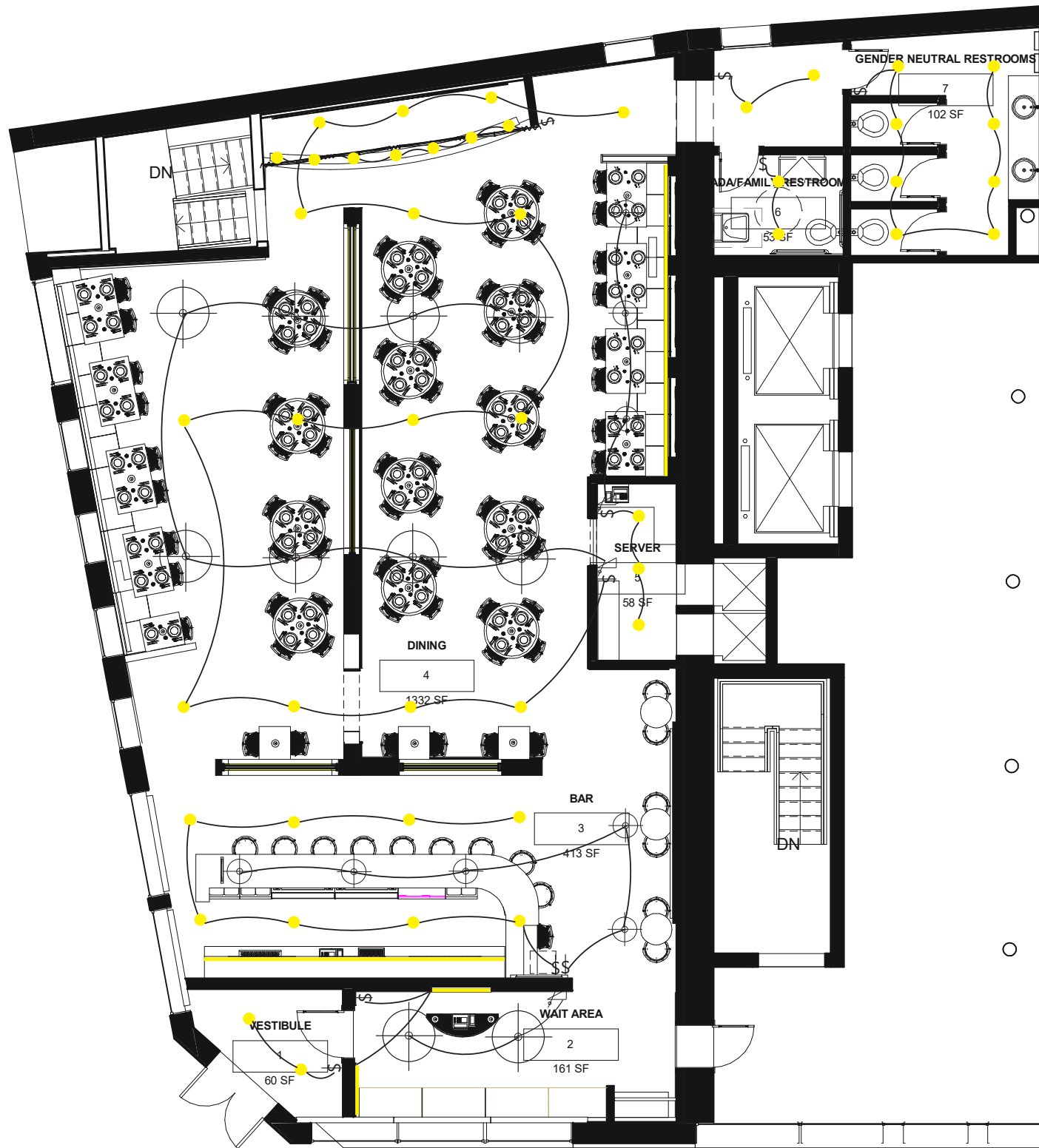
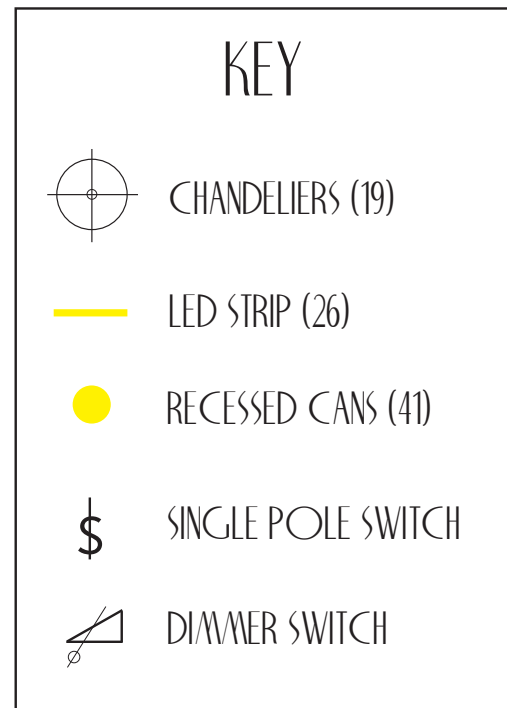

SWITCHING DIAGRAM

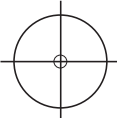

LUMINAIRE SCHEDULE AND KEY

SYMBOL	LABEL	QTY.	DESCRIPTION	MOUNTING	ILLUMINANCE	COLOR TEMP.	WATTAGE
	A	27	BACCARAT TORCH LAMP	TABLE	15 lx	3200K	12W
	B	26	ELATION FLEX LED TAPE WP	WALL MOUNT	86 lx	6500K	50W
	C	19	CALYPSO CHANDELIER	PENDANT	92 lx	3450K	72W
	D	41	RECESSED CAN LIGHTS	RECESSED	308 lx	2800K	60W

